



Assembly Instructions

Model: ADSGL-1

Step 1

Attach the seat to the sideframes using (6) 1½" bolts
Do not tighten bolts yet

Step 2

First Attach the back assembly *top* to the sideframes using
(2) ¾" bolts
Next attach the back assembly *bottom* to the seat using
(2) 1½" bolts

Step 3

Connect the glider frames to the braces
using (4) 2¼" bolts

Step 4

Attach the glider frame to the chair using
(4) 1½" bolts
Tighten all bolts at this time

- (2) Sideframes
- (1) Seat
- (1) Back
- (2) Brace
- (2) Glider frame
- (1) Hardware pack

TOOLS NEEDED

Phillips head screwdriver or
5/32" hex key

Qty.	Description
------	-------------

12	A - 1½" Bolt
4	B - 2¼" Bolt
2	C - ¾" Bolt

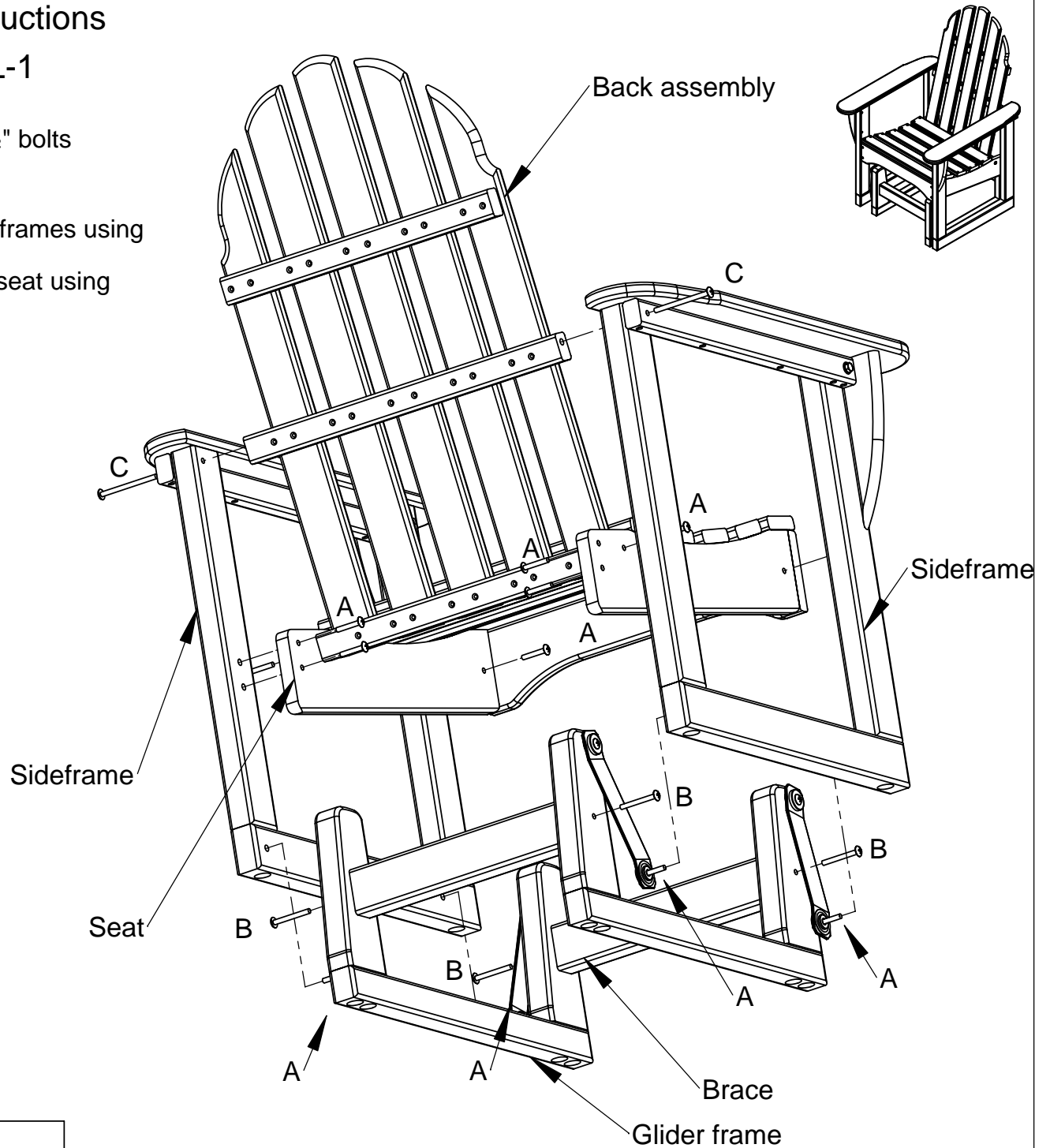

All bolts are 1/4-20

7/24/07