

Recycled POLY-WOOD Inc.

ASSEMBLY INSTRUCTIONS
Model - BAB48

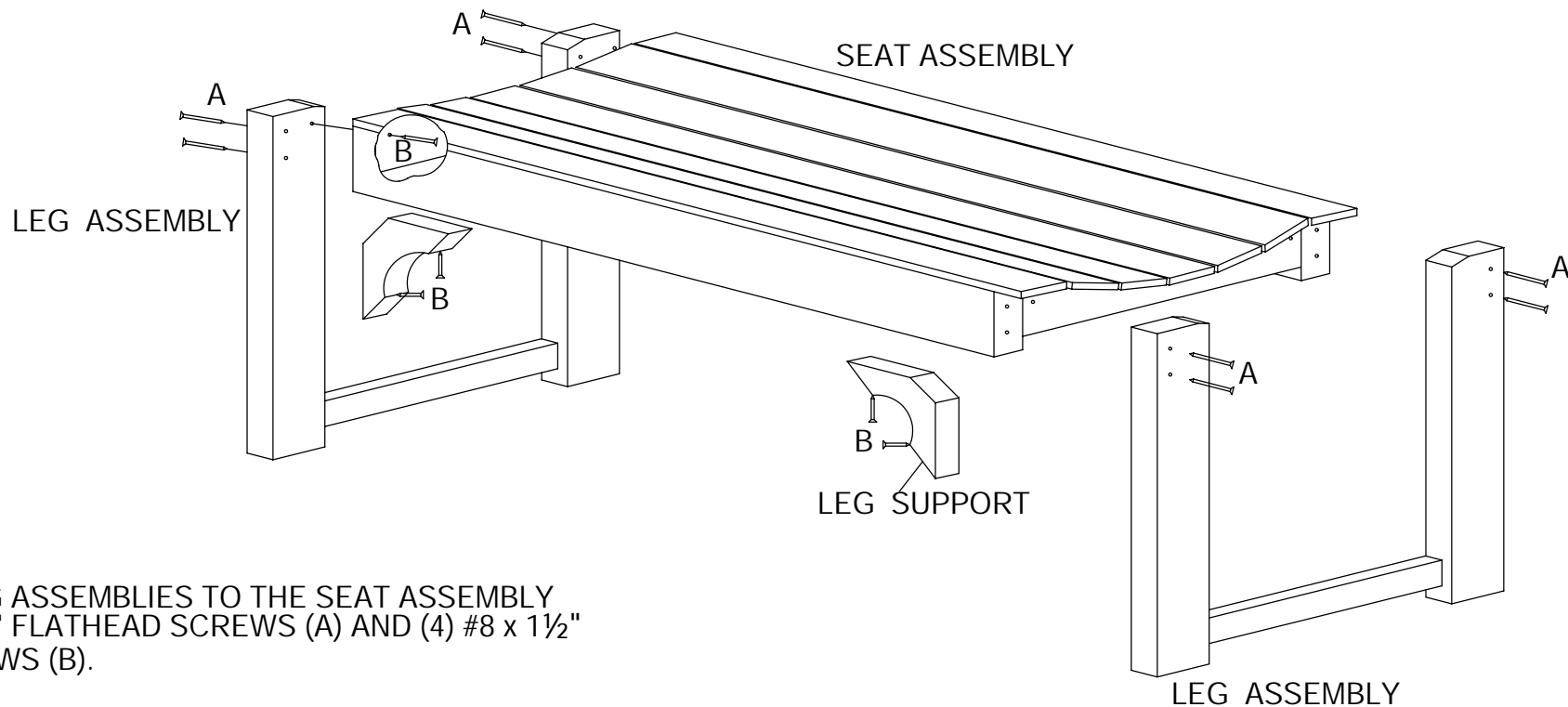

STEP 1

ATTACH THE LEG ASSEMBLIES TO THE SEAT ASSEMBLY USING (8) #10 x 3" FLATHEAD SCREWS (A) AND (4) #8 x 1½" FLATHEAD SCREWS (B).

STEP 2

ATTACH THE LEG SUPPORTS USING (8) #8 x 1½" FLATHEAD SCREWS IN PRE-DRILLED HOLES (B).

LETTER	QTY.	DESCRIPTION
A	8	#10 x 3" FLATHEAD SCREWS
B	12	#8 x 1½" FLATHEAD SCREWS

TOOLS NEEDED

PHILLIPS HEAD SCREWDRIVER
A SCREW GUN IS RECOMMENDED