



**Assembly Instructions**  
**Model: SHAD**

- \_\_\_ (1) Hardware pack
- \_\_\_ (1) Seat assembly
- \_\_\_ (1) Back assembly
- \_\_\_ (1) Front leg assembly
- \_\_\_ (2) Arm assembly

**TOOLS NEEDED**

- 7/16" Wrench
- Phillips head screwdriver or
- 5/32" hex key

**Step 1**

Place the seat assembly on the floor  
 Attach the front legs using  
 (2) 2½" bolts with washers and nuts

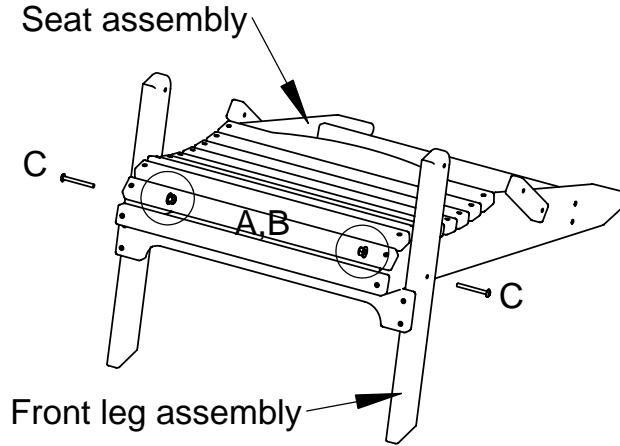

**Step 2**

Attach the bottom of the back assembly to the seat assembly using  
 (2) 3" Lag bolts with washers.

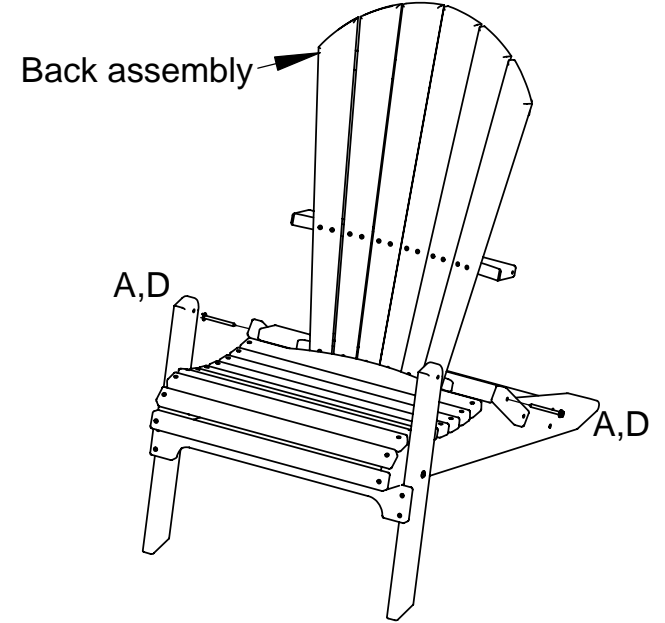

**Step 3**

Attach the arms to the front legs using  
 (2) 2½" bolts with washers and nuts.

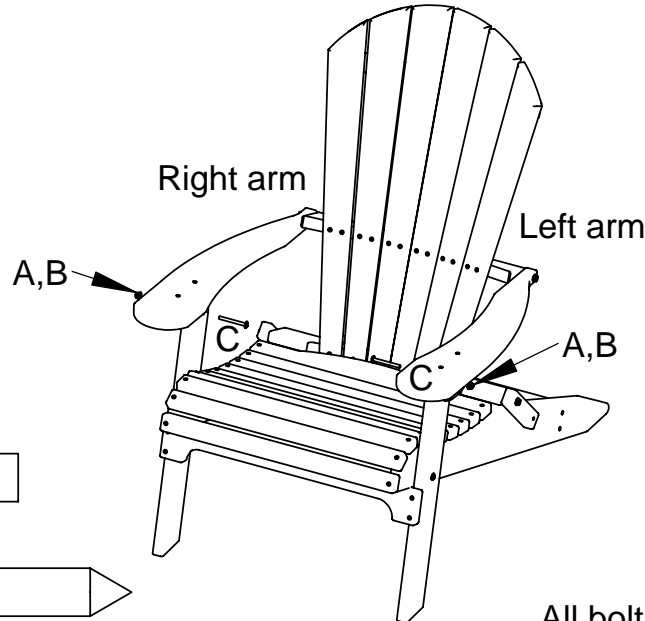

**Step 4**

Attach the arms to the back assembly using  
 (2) 3" Lag bolts with washers

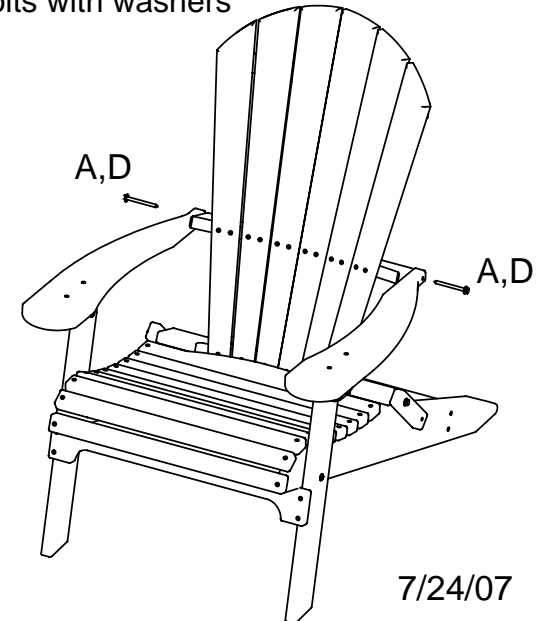

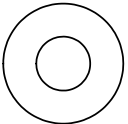
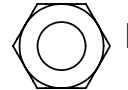
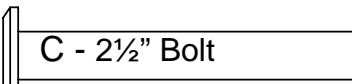
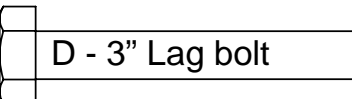
Qty.	Description
8	 A - 1/4" washer
4	 B - 1/4" nut
4	 C - 2½" Bolt
4	 D - 3" Lag bolt

All bolts are 1/4"

7/24/07